



Montage- und Gebrauchsanweisung , Installatie- en gebruiksaanwijzing, Notice d'utilisation et d'installation

EFC 9404 - 9412 - 9408

EFC 6404 - 6412

Operating and Installation Instructions, Instrucciones de montaje y manejo, Manual de Instruções

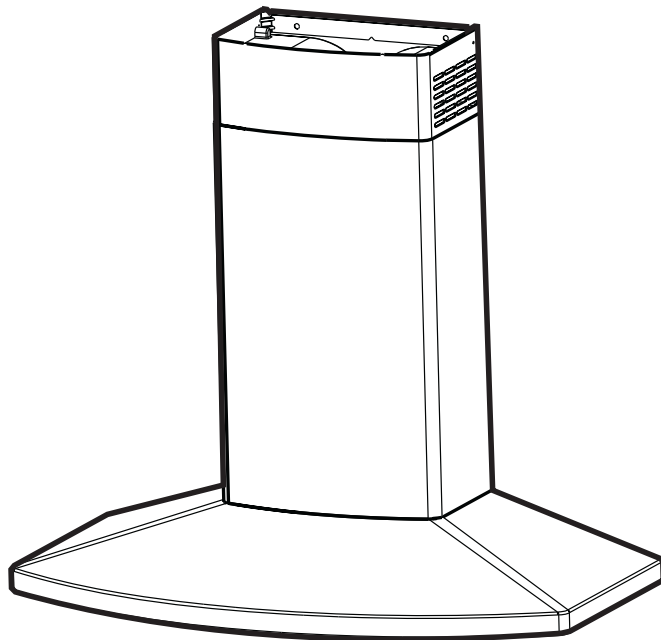

D

NL

F

UK

E

P

Safety warnings	39
For the installer	39
For the user	39
Description of the Appliance	40
Extractor version	40
Recirculation Version	40
Control Panel	41
Correct ventilation	41
Maintenance and Care	42
Cleaning the hood	42
Metal grease filter	42
Charcoal filter	43
Changing the light bulb	44
Something Not Working	45
Special accessories	45
Service and Spare Parts	46
Guarantee Conditions	47
Technical Specifications	48
Installation	48
Unpacking	48
Fitting	48
Electrical connection	48
Mounting accessories included	49
Wall unit mounting	49

Before installing or using this appliance please read this instruction book carefully paying particular attention to the safety warnings on the following page.

If you have any queries regarding this appliance please contact Customer Care for advice.

Please keep this instruction book for future reference and pass it on to any future owner of the appliance.



Safety warnings

For the installer

- When used as an extractor unit, the hood must be fitted with a 150mm diameter hose.
Attention: The hose is not supplied and must be purchased separately.
- **When installing the hood, make sure you respect the following minimum distance from the top edge of the cooking hob/ring surfaces:**

electric hobs	500 mm
gas hobs	650 mm

The hood can be installed above these heights but for optimum performance it should be installed at the distance quoted for the appropriate heat source.
- The national Standard on fuel-burning systems specifies a maximum depression of 0.04 mbar in such rooms.
- The air outlet must not be connected to chimney flues or combustion gas ducts. The air outlet must under no circumstances be connected to ventilation ducts for rooms in which fuel-burning appliances are installed.
- The air outlet installation must comply with the regulations laid down by the relevant authorities.
- When the unit is used in its extractor version, a sufficiently large ventilation hole must be provided, with dimensions that are approximately the same as the outlet hole.
- National and regional building regulations impose a number of restrictions on using hoods and fuel-burning appliances connected to a chimney, such as coal or oil room-heaters and gas fires, in the same room.
- Hoods can only be used safely with appliances connected to a chimney if the room and/or flat (air/environment combination) is ventilated from outside using a suitable ventilation hole approximately 500-600 cm² large to avoid the possibility of a depression being created during operation of the hood.
- If you have any doubts, contact the relevant controlling authority or building inspector's office.
- Since the rule for rooms with fuel burning appliances is "outlet hole of the same size as the ventilation hole", a hole of 500-600 cm², which is to say a larger hole, could reduce the performance of the extractor hood.
- If the hood is used in its filtering function, it will operate simply and safely in the above conditions without the need for any of the

aforementioned measures.

- When the hood is used in its extractor function, the following rules must be followed to obtain optimal operation:
 - short and straight outlet hose
 - keep bends in outlet hose to a minimum
 - never install the hoses with an acute angle, they must always follow a gentle curve.
 - keep the hose as large as possible (preferably the same diameter as the outlet hole).
- Failure to observe these basic instructions will drastically reduce the performance and increase the noise levels of the extractor hood.

For the user

- The cooker hood is designed to extract unpleasant odours from the kitchen, it will not extract steam.
- Always cover lighted elements, to prevent excess heat from damaging the appliance. In the case of oil, gas and coal fired cookers it is essential to avoid open flames.
- Also, when frying, keep the deep frying pan on the cooker top/cooker under careful control.
- The hot oil in the frying pan might ignite due to overheating.
- The risk of self-ignition increases when the oil being used is dirty.
- It is extremely important to note that overheating can cause a fire.
- **Never carry out any flambé cooking under the hood.**
- **Always disconnect the unit from the power supply before carrying out any work on the hood, including replacing the light bulb** (take the cartridge fuse out of the fuse holder or switch off the automatic circuit breaker).
- **It is very important to clean the hood and replace the filter at the recommended intervals. Failure to do so could cause grease deposits to build up, resulting in a fire hazard.**
- The appliance is not intended for use by young children or infirm persons without supervision.
- Young children should be supervised to ensure that they do not play with the appliance.
- **WARNING** - Ensure that the appliance is switched off before replacing the lamp to avoid the possibility of electric shock.

Description of the Appliance

- The hood is supplied as an extractor unit and can also be used with a filtering function by fitting one charcoal filter.
- You will need an original charcoal filter for this function (Available from your local Service Force Centre).

Only for EFC 9408

Attention! This model is already fitted with charcoal filter.

Extractor version

- In this version fumes are extracted to the outside via a hose connected to the coupling ring **A**. **Fig. 1**.
- In order to obtain the best performance the hose should have a diameter equal to the outlet hole.

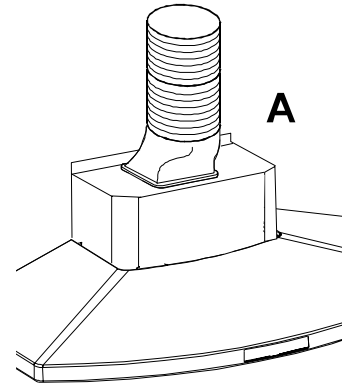

Fig. 1

Filter Version

- The air is filtered through an charcoal filter and returned to the kitchen through the top grill of the outlet pipe.
- You will need an original charcoal filter for the filtering function. (See Special Accessories).
- Fix the deflector using 2 screws $\text{\O} 2,9 \times 13$ mm. **Fig. 2**.
- Optionally, the position of the chimney elements can be changed.

When using the hood in the filter version the chimney must be fixed at the top, with the air outlet grill at the side.

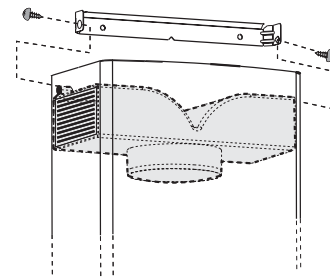

Fig. 2

Control Panel

- Best results are obtained by using a low speed for normal conditions and a high speed when odours are more concentrated.
Turn the hood on a few minutes before you start cooking, you will then get an under pressure in the kitchen. The hood should be left on after cooking for about 15 minutes or until all the odours have disappeared. The control switches are located on the unit's front panel:

EFC 9404-6404-9408

- A** - Mains switch, OFF.
- B** - Start and choice of motor speed 1-2-3-1-2.....
- C** - Indicates speed 1 (LED).
- D** - Indicates speed 2 (LED).
- E** - Indicates speed 3 (LED).
- F** - Indicates Intensive speed (LED).
- G** - Intensive speed on/off. The Intensive speed runs for 5 minutes:
If the hood is on when the Intensive speed is activated, the hood reverts to previous speed after 5 minutes.
If the hood is off when the Intensive speed is activated, the hood will be turned off after 5 minutes.
To interrupt the Intensive speed, press button A or B.
- H** - Light ON/OFF

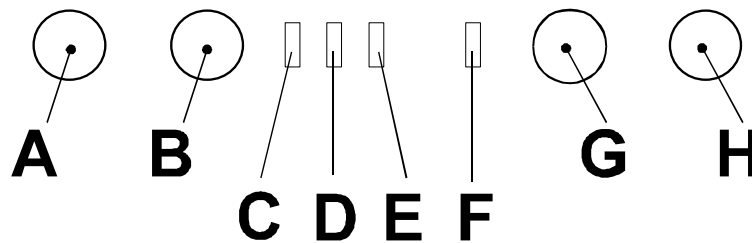

Should the hood or the controls fail to operate: disconnect the power supply for at least 5 seconds, then turn the hood back on again.

EFC 9412 - EFC 6412

- the **light switch** switches the hood lamp on and off
- the **motor switch** switches the motor on and off, enabling you to select one of the three different speeds.

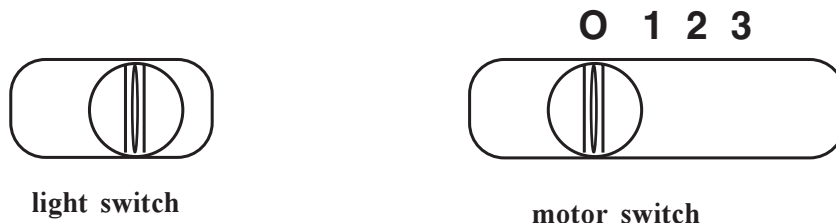

Correct ventilation

If the cooker hood is to work correctly there must be an under pressure in the kitchen. It is important to keep the kitchen windows closed and have a window in an adjacent room open.

Maintenance and Care

- The hood must always be disconnected from the electricity supply before beginning any maintenance work.

Cleaning the hood

- Clean the outside of the hood using a damp cloth and a mild detergent.
- Never use corrosive, abrasive or flammable cleaning products.
- Never insert pointed objects in the motor's protective grid.
- Wash the outside surfaces using a delicate detergent solution. Never use caustic detergents or abrasive brushes or powders.
- Only ever clean the switch panel and filter grille using a damp cloth and delicate detergents.
- It is extremely important to clean the unit and change the filters at the recommended intervals. Failure to do so will cause grease deposits to build up that could constitute a fire hazard.

Warning

- Failure to observe the instructions on cleaning the unit and changing the filters will cause a fire hazard. You are therefore strongly recommended to follow these instructions.
- The manufacturer declines all responsibility for any damage to the motor or any fire damage linked to inappropriate maintenance or failure to observe the above safety recommendations..

Metal grease filter

- The purpose of the grease filters is to absorb grease particles which form during cooking and it **must** always be used, either in the external extraction or internal recycling function.
Attention: the metal grease filters must be removed and washed, either by hand or in the dishwasher, every four weeks.

Removing the metal grease filter

- First, push the metal grease filter stop backwards, then extract the filter, pulling downwards. **Fig. 3.**

Hand washing

Soak grease filters for about one hour in hot water with a little washing-up liquid, then rinse off thoroughly with hot water. Repeat the process if necessary. Refit the grease filters when they are dry.

Dishwasher

Place grease filters in the dishwasher. Select most powerful washing programme and highest temperature, at least 65°C. Repeat the process. Refit the grease filters when they are dry.

When washing the metal grease filter in the dishwasher a slight discolouration of the filter can occur, this does not have any impact on its performance.

- Clean the inner housing using a hot detergent solution only (never use caustic detergents, abrasive powders or brushes).

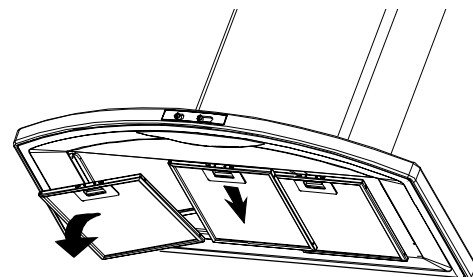

Fig. 3

Charcoal filter

- The charcoal filter should only be used if you want to use the hood in the recirculation function.
- To do this you will need an original charcoal filter (available from your local Service Force Centre).
- **Cleaning/replacing the charcoal filter**
Unlike other carbon filters, the LONGLIFE carbon filter can be cleaned and reactivated. At normal use the filter should be cleaned every second month (when using the hood 2,5 hours per day, in average). The best way to clean the filter is in the dishwasher. Use normal detergent and choose the highest temperature (65° C). Wash the filter separately so that no food parts gets stuck on the filter and later causes bad odours. To reactivate the charcoal, the filter should be dried in an oven for 10 minutes with a temperature of maximum 100° C.
After approximately three years of use, the charcoal filter should be replaced with a new, as the odour reduction capacity will be reduced.
- **Mounting - Fig. 4**
Put the charcoal filter frame in place and fix it with 5 screws.
Fit the charcoal filter first from the rear side and fix it frontwards using the two red keys A.
- **To remove** proceed in the reverse order.
- Always specify the hood model code number and serial number when ordering replacement filters. This information is shown on the registration plate located on the inside of the unit.
- The charcoal filter can be ordered from your local Service Force Centre.

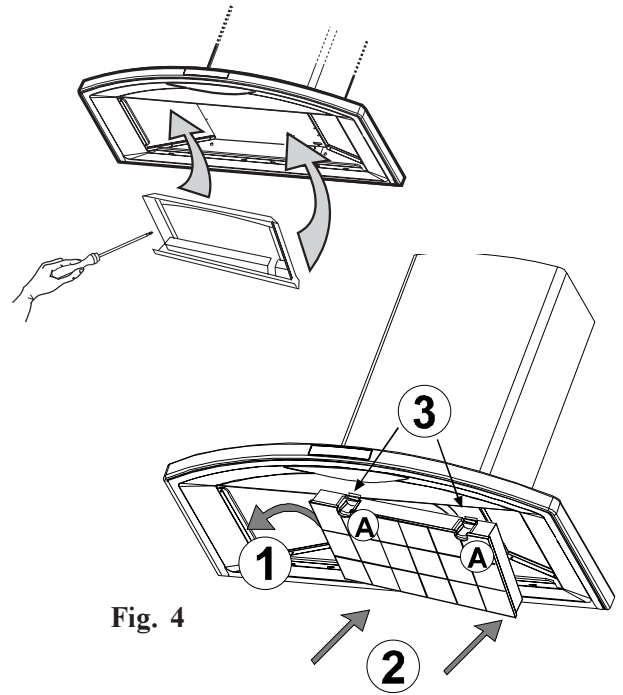

Fig. 4

Changing the light bulb

- Disconnect the cooker hood from the mains supply.

EFC 9412 - 6412

- Remove the lamp cover. **Fig. 5.**
- Replace the old bulb with a new one of the same type.
- Remount the lamp cover.

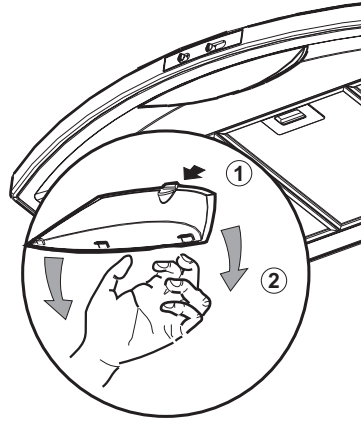

Fig. 5

EFC 9408-9404-6404

- Press (1) the lamp cover (2) and open it. **Fig. 6.**
- Replace the old bulb with a new one of the same type (3).
- Close the lamp cover.

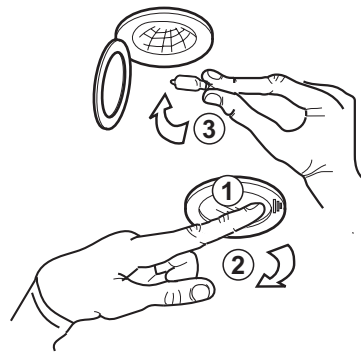

Fig. 6

- If the light does not come on, make sure the bulb has been inserted in correctly before contacting your local Service Force Centre.

What to do if

If your appliance fails to work properly please carry out the following checks.

Symptom	Solution
The cooker hood will not start...	Check that: The hood is connected to the electricity supply. Check that a fan speed has been selected
The cooker hood is not working	Check that: The fan speed is set high enough for the task. The grease filters are clean. The kitchen is adequately vented to allow the entry of fresh air. If set up for recirculation, check that the charcoal filter is still effective. If set up for extraction, check that the ducting and outlets are not blocked.
The cooker hood has switched off during operation...	The safety cut-out device has been tripped. Turn off the hob and then wait for the device to reset. If the hood has been installed below the heights indicated in the installation instructions the motor will cut-out frequently which will damage the hood.

If after all these checks, the problem persists, contact your local Service Force Centre, quoting the model and serial number.

Please note that it will be necessary to provide proof of purchase for any in-guarantee service calls.

In-guarantee customers should ensure that the above checks have been made as the engineer will make a charge if the fault is not a mechanical or electrical breakdown.

Special Accessories

Charcoal Filter Type 150 LONG LIFE

Technical assistance service

You are welcome to telephone our technical assistance service (see list of technical assistance centres) whenever you need information or in the unlikely event of a fault.

For service in Australia call 1300 650 020.

When calling, please be ready to specify:

1. **The model code number**
2. **The serial number (E-Nr.)**
3. **The manufacturing number (F-Nr.)**

This information is shown on the registration plate inside the unit behind the grease filter.

We reserve the right to change specifications and colours as a result of our policy of continuing technological development.

Service and Spare Parts

In the event of your appliance requiring service, or if you wish to purchase spare parts, contact your local Service Force Centre by telephoning: **08705 929 929**

Your call will be automatically routed to the Service Centre covering your post code area. For the address of your local Service Force Centre and further information about Service Force, please visit the website at www.serviceforce.co.uk

Please ensure that you have read the section „What to do if...“ as the engineer will make a charge if the fault is not a mechanical or electrical breakdown even the appliance is under warranty. **Please note that proof of purchase is required for in-guarantee service calls.**

Help us to help you

Please determine your type of enquiry before writing or telephoning.

When you contact us we need to know:

- Your name
- Address and post code
- Telephone number
- Clear and concise details of the fault
- Name and model of the appliance*
- E number*
- Serial number*

* This information can be found on the rating plate, which can be seen when the grease filters are removed.

If you require Customer Service in the Republic of Ireland please contact us at the address below:

Electrolux
Electrolux Group (Ire) Ltd
Long Mile Road
Dublin 12
Republic of Ireland

Tel: + 353 (0) 1 4090751

Email: service.eid@electrolux.ie

CUSTOMER CARE DEPARTMENT

For general enquiries concerning your AEG appliance or for further information on ELECTROLUX products, please contact our Customer Care Department by letter or telephone at the address below or visit our website at www.electrolux.co.uk

Customer Care Department
Electrolux
55-77 High Street
Slough, Berkshire
SL1 1DZ
08705 950950 (*)

* calls to this number may be recorded for training purposes.

Guarantee Conditions

Standard guarantee conditions

We, Electrolux, undertake that if within 12 months of the date of the purchase this Electrolux appliance or any part thereof is proved to be defective by reason only of faulty workmanship or materials, we will, at our option repair or replace the same **FREE OF CHARGE** for labour, materials or carriage on condition that:

The appliance has been correctly installed and used only on the electricity supply stated on the rating plate.

The appliance has been used for normal domestic purposes only, and in accordance with the manufacturer's instructions.

The appliance has not been serviced, maintained, repaired, taken apart or tampered with by any person not authorised by us.

All service work under this guarantee must be undertaken by an Electrolux Service Force Centre. Any appliance or defective part replaced shall become the Company's property.

This guarantee is in addition to your statutory and other legal rights.

Home visits are made between **8.30am and 5.30pm** Monday to Friday.

Visits may be available outside these hours in which case a **premium** will be charged.

Exclusions

This guarantee does not cover:

Damage or calls resulting from transportation, improper use or neglect, the replacement of any light bulbs or removable parts of glass or plastic.

Costs incurred for calls to put right an appliance which is improperly installed or calls to appliances outside the European Community (EC) or European Free Trade Area.

Appliances found to be in use within a commercial environment, plus those which are subject to rental agreements.

Products of Electrolux manufacture which are not marketed by Electrolux.

European Guarantee

If you should move to another country within Europe then your guarantee moves with you to your new home subject to the following qualifications:

The guarantee starts from the date you first purchased your product.

The guarantee is for the same period and to the same extent for labour and parts as exists in the new country of use for this brand or range of products.

This guarantee relates to you and cannot be transferred to another user.

Your new home is within the European Community (EC) or European Free Trade Area.

The product is installed and used in accordance with our instructions and is only used domestically, i.e. a normal household.

The product is installed taking into account regulations in your new country.

Before you move please contact your nearest Customer Care centre, listed below, to give them details of your new home. They will then ensure that the local Service Organisation is aware of your move and able to look after you and your appliances.

France	Senlis	+33 (0)3 44 62 20 13
Germany	Nürnberg	+49 (0)800 234 7378
Italy	Pordenone	+39 (0) 800 117511
Sweden	Stockholm	+46 (0)20 78 77 50
UK	Slough	+44 (0) 1753 219898

Technical Specifications

Model:	EFC9404	EFC6404	EFC9412	EFC6412	EFC9408
Dimensions (in cm):					
Height (Filter Version)	82-127,5(82-137)	82-125,5(80-135)	82-127,5(82-137)	82-125,5(80-135)	82-127,5(82-137)
Width	89,8	59,8	89,8	59,8	89,8
Depth	48	48	48	48	48
Max. absorbed power:	290 W	290 W	180 W	180 W	290 W
Motor absorption:	250 W	250 W	170 W	170 W	250 W
Lighting:	2 x 20 W	2 x 20 W	11 W	11 W	2 x 20 W
Length of the cable:	150 cm	150 cm	150 cm	150 cm	150 cm
Electrical connection:	220-240 V	220-240 V	220-240 V	220-240 V	220-240 V

Subject to change without notice.

Installation

Unpacking

Check that the cooker hood has no damages. Transportation damages should immediately be reported to the company responsible for the transportation. Damages, faults and eventually missing details should immediately be reported to the retailer. Take care of the packing materials so that small children cannot play with them.

Fitting

The hood is to be mounted on the wall. When installed, the hood must be not less than 50 cm. above electric burners or 65 cm. above gas or mixed-fuel burners. The hood can be installed above these heights but for optimum performance it should be installed at the distance quoted for the appropriate heat source.

Electrical connection (not for UK)

Safety warnings for the electrician
Before connecting the appliance to the power supply, check that the voltage indicated on the rating plate corresponds to the mains power supply available. Appliances fitted with a plug can be connected to any standard power socket within easy access. Should it be necessary to provide a fixed connection, the hood must only be installed by an electrician authorised by the local electricity board. When installing, an omnipolar disconnecter with a distance of at least 3 mm between contacts must be provided. Fixed connection of the appliance must only be carried out by an authorised electrician.

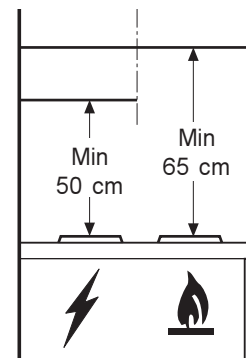

Fig. 7 - Fitting

Electrical connection for UK only

Safety warnings for the electrician

Connect the hood to the mains supply via a double pole switch which has 3 mm minimum separation between the contacts.

The switch must be accessible at all times.

The following is valid in the United Kingdom only:

- the wire which is coloured green and yellow must be connected to the terminal which is marked with the letter E or by the earth symbol (\perp), or coloured green or green and yellow;
- the wire which is coloured blue must be connected to the terminal which is marked with the letter N or coloured black, -
- the wire which is coloured brown must be connected to the terminal which is marked with the letter L or coloured red.

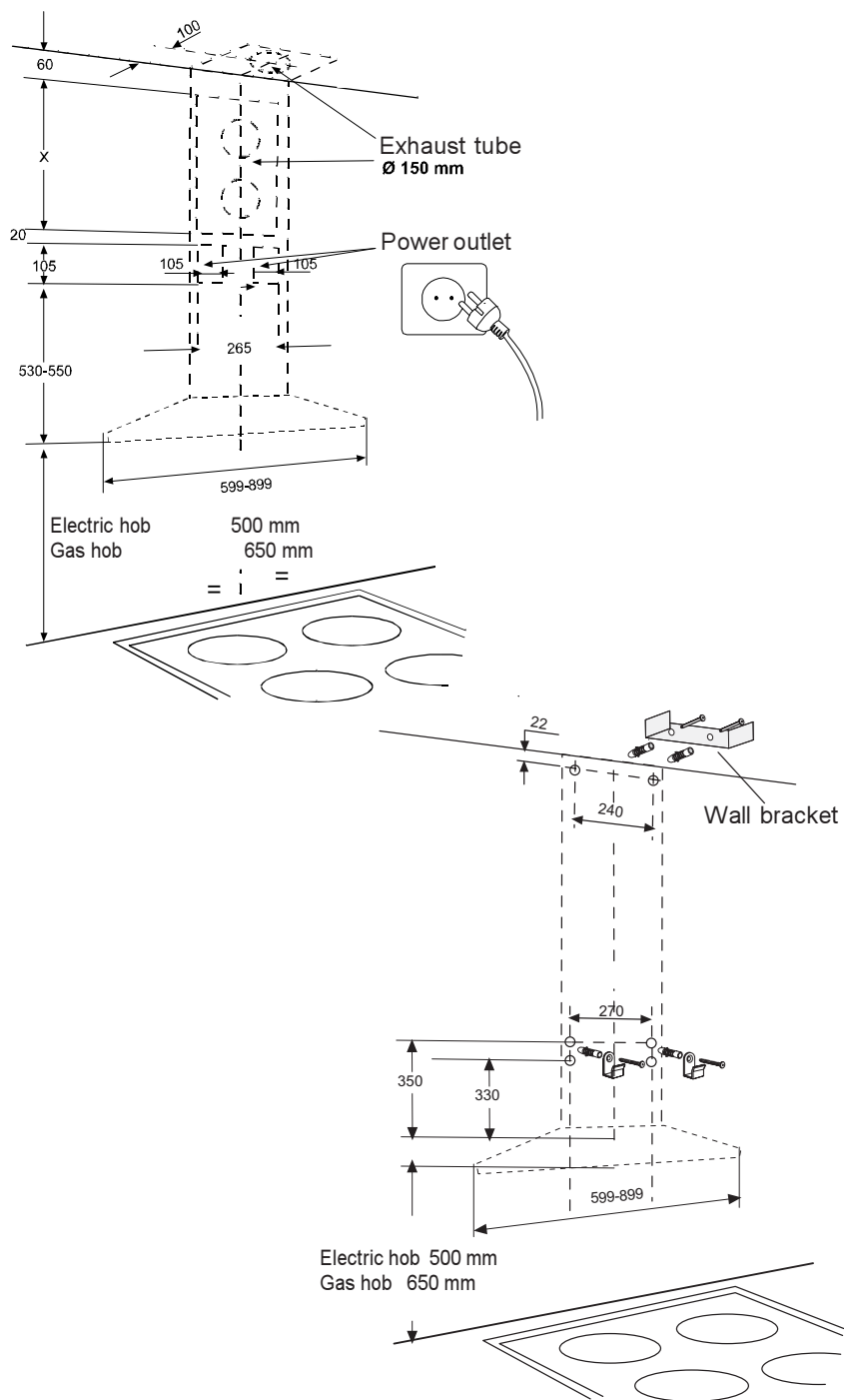



Electrolux

 **The Electrolux Group. The world's No.1 choice.**

The Electrolux Group is the world's largest producer of powered appliances for kitchen, cleaning and outdoor use. More than 55 million Electrolux Group products (such as refrigerators, cookers, washing machines, vacuum cleaners, chain saws and lawn mowers) are sold each year to a value of approx. USD 14 billion in more than 150 countries around the world.