

You are at the heart of everything we do.

At Electrolux, every product we make is designed to help you find a little more time, endure a little less stress and discover a little more well being.



Share more of our thinking at www.electrolux.com.hk



f Electrolux Hong Kong | Q

Electrolux Home Care Service

- 5 years full warranty for 2-door & 3-door refrigerator / 3 years full warranty for side-by-side refrigerator
- 10 years warranty on inverter compressor
- 60 days free machine replacement for defective items
- Free delivery to building without elevator (exclude over 400L fridges)
- Free removal of used machine (exclude over 400L fridges)
- 5年全機保養 (2門及3門雪櫃) / 3年全機保養 (對門雪櫃)
- 10年變頻壓縮機保養
- 60日壞機包換
- 免費無電梯送貨服務 (只限樓宇內, 不包括400公升以上大型雪櫃)
- 免費代棄舊機服務 (不包括400公升以上大型雪櫃)

Please refer to our website for detail service terms & conditions:

服務範圍及各事項詳情, 請參閱:

www.dch-ead.com

Sole Agent:

DAH CHONG HONG, LTD.

8/F., DCH Building, 20 Kai Cheung Road,
Kowloon Bay, Hong Kong
Tel: 2262 1621

售後服務熱線
Service Hotline: **3193 9888**



總代理:

大昌貿易行有限公司

香港九龍灣啟祥道20號大昌行集團大廈八樓
電話: 2262 1621

Electrolux 06/18/2K



變頻 
極致保鮮

NUTRIFRESH™ INVERTER

伊萊克斯變頻雪櫃系列

NutriFresh™ Refrigeration

2018 Edition



Electrolux NutriFresh™ fridges have innovative features that give flexibility in storing your food so you can enjoy their wholesome goodness and freshness.

Electrolux introduces the **NutriFresh™** line of fridges which understands your desire for a healthier and fresher lifestyle by introducing a myriad of features that let you do just that. Cool new features such as **FlexStor™** and **FreshLogic** enable you to have flexibility in storing your food keeping them fresher longer so that you can enjoy their wholesome goodness without compromise. Awarded with Grade 1 in Mandatory Energy Efficiency Label (MEEL), the new **Electrolux** fridge range reduces energy consumption.

伊萊克斯深明您對新鮮食材和健康生活的追求，推出全新 **NutriFresh™** 雪櫃系列，集結多種高科技功能，如靈活配置設備及智能調控面板等貼心設計，不但方便存取食材，更有效延長食物保鮮時間。全線伊萊克斯雪櫃系列更榮獲機電工程署一級能源標籤，節能環保。



ENERGY LABEL 能源標籤	
more efficient 效益較高	Grade 1 級
1	
2	
3	
4	
5	
less efficient 效益較低	
Annual Energy Consumption (kWh) 年耗電量 (千瓦時)	265
Fresh Food Volume (litre) 新鮮食物容量 (公升)	257
Frozen Food Volume (litre) 凍肉食物容量 (公升)	75
Refrigerating Appliance Brand 品牌	Electrolux 伊萊克斯
Model Reference Number / Year 型號 / 參考編號 / 年份	EMES0008G U1-#160194 / 2014
Information Provider 資料提供機構	D&W Chang Hong Ltd. 大鴻昌貿易有限公司
機電工程署 EMSD	



TRUSTED IN
EUROPE
FOR NEARLY
100
YEARS

NUTRIFRESH INVERTER
compressor

Features 雪櫃功能及優點

NUTRI FRESH INVERTER

NutriFresh™ Inverter Technology 極致保鮮變頻技術

An upgraded compressor prevents temperature fluctuations in order to better maintain food freshness and save energy. Through this technique, it reduces up to 37% energy consumption* and it's much quiet.

* Compared with previous models

全新升級變頻壓縮機，穩定溫度變化，避免食材因溫度變化太大而影響保鮮期。同時，變頻壓縮機能有效減少37%的能源消耗*，既能保持食材新鮮又能節省用電，運作時更寧靜及安心。

* 與其他較早期型號比較



10 Year Warranty 變頻壓縮機10年保養

Enjoy peace of mind with our promise of durability. Our NutriFresh™ Inverter refrigerators offer a 10 Year Warranty on the compressor (parts only).

伊萊克斯對產品的嶄新技術及耐用性充滿信心，為全系列 NutriFresh™ 變頻壓縮機提供10年保養。



Fresh Taste Deodorizer 防菌淨味系統

A system of Deodorizers attract and absorb stray odours & strong smells from one food mixing with that of others and eliminated 99.8% of bacteria*.

* Independent lab test by Guang Dong Detection Centre of Microbiology.

防菌淨味系統可減少99.8%引致異味的細菌滋生*，保持食材新鮮衛生，同時避免強烈氣味影響其他食物的味道，時刻保持新鮮。

* 獨立測試由廣東省微生物分析檢測中心進行



FreshLogic 智能調控面板

The user interface on door with multiple functionalities including temperature control and other features, and all detail is clearly visible; then you can control the refrigerator conveniently.

設置於雪櫃上的智能調控面板，讓您無須開啟雪櫃亦能靈活操作不同功能及調節雪櫃溫度，同時對雪櫃運作狀況一目了然。



Market Fresh Crisper 蔬果保鮮格

A special designed box cover with adjustable humidity control enables to keep the vegetable and fruits from drying out and preserve the nutrient, thus ensure vegetable and fruits as stay market fresh longer.

特殊設計盒蓋，可按個人需要調控濕度，鎖定蔬果的水份及維他命，舒緩蔬果的枯萎速度，使蔬果結實及清脆，同時保留蔬果的豐富營養，達至最理想的保鮮效果。



360° Dynamic Air Flow Side Cooling 360 度全方位送風冷凍系統

Multi-level air vents sited in rear and left-right panels that constant air circulation throughout the refrigerator and freezer, so that consistent temperature is maintained with no warm spots.

於雪櫃背壁及左右兩側設有多層出風口，以層層出風的方法確保冷空氣遍佈雪櫃每個角落，保持溫度均勻穩定，即使食物放置任何位置，都依然得到最佳冷凍效果。



* Above descriptions only apply to particular model.
以上功能視乎型號。

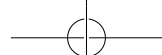

FlexStor™ 靈活配置

Now you don't have to worry about accommodating large serving bowls or trays. Electrolux's adjustable shelves and bins give you the flexibility to store your food your way. Flexible compartments in the doors move from side to side, and up and down, to make room for the tallest bottles. Unique features like Bag Clips help you hang storage bags straight from the marketplace for easy access.

設有活動式強化的玻璃層格與保鮮格，讓您能夠靈活調動儲存食物的空間。雪櫃門上的活動式儲物格，可以左右上下移動，能夠輕易騰出空間儲存高身瓶裝飲品。另外，門上亦設有伊萊克斯獨有的夾子，讓您可以直接把市場帶回來的購物袋掛在門上，方便省時。



Holiday Mode 假日省電模式

Holiday mode is designed to take advantage of maximum energy efficiency when you will be away from your appliance for an extended period. Auto-alteration will start after 30hrs no human interaction.

當超過30小時沒有開啟雪櫃或觸控智能面板，自動調節模式將會啟動，設備將以最少電量運作，確保食物質素。



FlexFresh™ Compartments 獨立變溫室

Unique flexible temperature compartment which can be configured to store a variety of refrigeration requirements from storing fruits & vegetable to meat/fish/poultry items and also food items which need soft freezing. (Storage temperature -12°C to 3°C)

不論是儲存蔬果、肉類或海鮮，或是需要溫和冷凍的食物，獨立變溫室都可以讓您根據不同需要，靈活調節溫度，由-12°C至3°C的溫度轉換，為您提供更多空間選擇，方便靈活。



Door Alarms 關門響鬧提示

Door alarm which ensures that your refrigerator can never be accidentally left open. Now you can save energy without compromising on safe food storage.

不用再擔心忘記關上雪櫃門了，當雪櫃門開啟超過2分鐘，會自動發出響鬧提示關門，避免因為雪櫃門未關而增加耗電，或是令食物變壞。



FlexSpace 靈活空間

Shelving system with foldable bin enables to increase the storage space in the freezer compartment, now you can store the larger containers more convenient.

冷凍室設有可摺式層架，可以靈活調動，輕易增加雪櫃內部空間，存放體積龐大的食品或容器，更為方便。



Quick Freeze Mode 快速冷凍模式

Use the quick freeze mode when you add a large amount of new fresh food to the freezer compartment. The freezer compartment temperature will reach to -23°C quickly. This quick freeze mode can retain the freshness and also avoid the new contents affect the temperature to existing contents.

當儲存大量食品時，快速冷凍模式可以使冷凍室溫度迅速降至-23°C，快速冷凍新鮮食物，同時亦可避免室溫食物影響冷凍室原有已存的食物溫度。



* Above descriptions only apply to particular model. 以上功能視乎型號。

ETB2600MG

2-door NutriFresh™ Refrigerator, Top Freezer
上置冰格式雙門變頻雪櫃

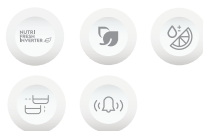

- NutriFresh™ Inverter Compressor
- Fresh Taste Deodorizer
- Crisper Bins
- FlexStor™
- Door Alarm
- Reversible Door (Advance Notice)

- 極致保鮮變頻壓縮機
- 防菌淨味系統
- 蔬果保鮮格
- 靈活配置：物件袋夾子及靈活儲存格
- 關門響鬧提示
- 可轉換左右門（需預先通知）

ETB3200MG/ETB3500MG

2-door NutriFresh™ Refrigerator, Top Freezer
上置冰格式雙門變頻雪櫃



- NutriFresh™ Inverter Compressor
- Fresh Taste Deodorizer
- Crisper Bins
- 360° Dynamic Air Flow Side Cooling
- FlexStor™
- Door Alarm
- Reversible Door (Advance Notice)

- 極致保鮮變頻壓縮機
- 防菌淨味系統
- 蔬果保鮮格
- 360 度全方位送風冷凍系統
- 靈活配置：物件袋夾子及靈活儲存格
- 關門響鬧提示
- 可轉換左右門（需預先通知）



Gross / Net capacity: 275 / 255 Liters	總容量 / 淨容量: 275 / 255 公升
Fridge / Freezer capacity: 194 / 61 Liters	冷藏室 / 冷凍室容量: 194 / 61 公升
Dimensions (H x W x D) 1605 x 540 x 615 mm	體積 (高 x 闊 x 深) 1605 x 540 x 615 毫米
Freezer star rating: ***	冷凍室星級: ***
Color: Dark Grey	顏色: 銀影灰



Gross / Net capacity: 339 / 316 Liters (ETB3200MG) 369 / 348 Liters (ETB3500MG)	總容量 / 淨容量: 339 / 316 公升 (ETB3200MG) 369 / 348 公升 (ETB3500MG)
Fridge / Freezer capacity: 241 / 75 Liters (ETB3200MG) 273 / 75 Liters (ETB3500MG)	冷藏室 / 冷凍室容量: 241 / 75 公升 (ETB3200MG) 273 / 75 公升 (ETB3500MG)
Dimensions (H x W x D) 1645 x 598 x 650 mm (ETB3200MG) 1755 x 598 x 650 mm (ETB3500MG)	體積 (高 x 闊 x 深) 1645 x 598 x 650 毫米 (ETB3200MG) 1755 x 598 x 650 毫米 (ETB3500MG)
Freezer star rating: ***	冷凍室星級: ***
Color: Dark Grey	顏色: 銀影灰

EME2600MG

3-door NutriFresh™ Refrigerator, Top Freezer
上置冰格式三門變頻雪櫃



- NutriFresh™ Inverter Compressor
- Fresh Taste Deodorizer
- FreshLogic
- Crisper Bins
- 360° Dynamic Air Flow Side Cooling
- FlexFresh™ Compartments
- FlexStor™
- Drink Chill Mode
- Holiday Mode
- Quick Freeze Mode
- Door Alarm

- 極致保鮮變頻壓縮機
- 防菌淨味系統
- 智能調控面板
- 蔬果保鮮格
- 360 度全方位送風冷凍系統
- 獨立變溫室
- 靈活配置：物件袋夾子及靈活儲存格
- 飲品急凍模式
- 假日省電模式
- 快速冷凍模式
- 關門響鬧提示

Gross / Net capacity:
279 / 252 Liters

總容量 / 淨容量:
279 / 252 公升

**Fridge / Freezer /
FlexFresh capacity:**
149 / 62 / 41 Liters

冷藏室 / 冷凍室容量 /
獨立變溫室:
149 / 62 / 41 公升

Dimensions (H x W x D)
1745 x 540 x 615 mm

體積 (高 x 闊 x 深)
1745 x 540 x 615 毫米

Freezer star rating:

冷凍室星級:

Color: Dark Grey

顏色: 銀影灰



EME3500MG

3-door NutriFresh™ Refrigerator, Top Freezer
上置冰格式三門變頻雪櫃



- NutriFresh™ Inverter Compressor
- Fresh Taste Deodorizer
- FreshLogic
- Crisper Bins
- 360° Dynamic Air Flow Side Cooling
- FlexFresh™ Compartments
- FlexStor™
- FlexSpace
- Drink Chill Mode
- Holiday Mode
- Quick Freeze Mode
- Door Alarm

- 極致保鮮變頻壓縮機
- 防菌淨味系統
- 智能調控面板
- 蔬果保鮮格
- 360 度全方位送風冷凍系統
- 獨立變溫室
- 靈活配置：物件袋夾子及靈活儲存格
- 靈活伸展玻璃層架
- 飲品急凍模式
- 假日省電模式
- 快速冷凍模式
- 關門響鬧提示

Gross / Net capacity:
363 / 332 Liters

總容量 / 淨容量:
363 / 332 公升

**Fridge / Freezer /
FlexFresh capacity:**
206 / 75 / 51 Liters

冷藏室 / 冷凍室容量 /
獨立變溫室:
206 / 75 / 51 公升

Dimensions (H x W x D)
1855 x 598 x 650 mm

體積 (高 x 闊 x 深)
1855 x 598 x 650 毫米

Freezer star rating:

冷凍室星級:

Color: Dark Grey

顏色: 銀影灰



2-door / 3-door Nutrifresh Inverter Refrigerator series 雙門 / 三門極致保鮮變頻雪櫃系列

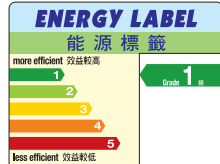

Model no.	型號	ETB2600MG	ETB3200MG	ETB3500MG	EME2600MG	EME3500MG
Gross/Net Capacity (Liter)	總容量/淨容量 (公升)	275 / 255	339 / 316	369 / 348	279 / 252	363 / 332
Fridge Capacity (Liter)	冷藏室容量 (公升)	194	241	273	149	206
Freezer Capacity (Liter)	冷凍室容量 (公升)	61	75	75	62	75
FlexFresh™ Compartment Capacity (Liter)	獨立變溫室容量 (公升)	-	-	-	41	51
Features	特點					
NutriFresh™ Inverter Technology	極致保鮮變頻技術	•	•	•	•	•
FreshLogic	智能調控面板	-	-	-	•	•
360° Dynamic Air Flow Side Cooling	360度全方位送風冷凍系統	-	•	•	•	•
FreshTaste Deodorizer	防菌淨味系統	•	•	•	•	•
ECO Mode	節能模式	-	-	-	•	•
Holiday Mode	假日模式	-	-	-	•	•
Drink Chill Mode	飲品急凍模式	-	-	-	•	•
Door Alarm	關門響鬧提示	•	•	•	•	•
Frost-free	無霜設計	•	•	•	•	•
Recessed Door Handle	隱藏式門柄	•	•	•	•	•
Fridge Functions	冷藏室功能					
Door Storage Bins (Shelves)	活動式層格	3	4	4	3	4
Door Storage Bins (Full Width)	特大層格 (高身飲品用)	2	2	2	2	2
Market Fresh Crisper	蔬果保鮮格	1	1	1	1	1
Fridge Glass Shelves	強化玻璃層架	2	3	3	3	3
Chill Room	保鮮室	•	•	•	-	•
Bag Clips/Hooks	專利門架夾子	1	2	2	2	2
Egg Tray	雞蛋儲存架	•	•	•	•	•
Interior Light	雪櫃照明燈	LED	LED	LED	LED	LED
Freezer Functions	冷凍室功能					
Quick Freeze Mode	快速冷凍模式	-	-	-	•	•
Door Storage Bins (Shelves)	活動式層格	2	2	2	2	2
FlexSpace	靈活伸展玻璃層架	-	-	-	-	•
Chill Room	冷凍室	-	-	-	-	•
Ice Tray	製冰格	•	•	•	•	•
Freezer Shelf	強化玻璃層架	1	1	1	1	1
Interior Light	雪櫃照明燈	-	-	-	-	LED
Other Features	其他特點					
Energy Efficiency Rating (Grade)	香港能源效益標籤 (級)	1	1	1	1	1
Freezer Star Rating	冷凍室星級	***	***	***	***	***
Refrigerant	環保雪種	R600a	R600a	R600a	R600a	R600a
Dimensions (H x W x D) mm	體積 (高 x 闊 x 深) 毫米	1605 x 540 x 615	1645 x 598 x 650	1755 x 598 x 650	1745 x 540 x 615	1855 x 598 x 650
Dimensions (H x W x D) inch	體積 (高 x 闊 x 深) 吋	63.2 x 21.3 x 24.2	64.8 x 23.5 x 25.6	69.1 x 23.5 x 25.6	68.7 x 21.3 x 24.2	73 x 23.5 x 25.6
Reversible Door (Advance notice)	可轉換左右門 (需預先通知)	•	•	•	-	-
Country of Origin	原產地	Thailand 泰國	Thailand 泰國	Thailand 泰國	Thailand 泰國	Thailand 泰國

* Specifications and design subject to change without notice.
All visual images are for reference only.

* 因改進而變更規格, 恕不另行通知。
所有圖片只供參考。

Side-by-side
NutriFresh™ Refrigerator
對門式雪櫃



ESE5301AG-MY / ESE6201BG-MY

Side-by-side NutriFresh™ Refrigerator
對門式變頻雪櫃



- NutriFresh™ Inverter Compressor
- Fresh Taste Deodorizer
- FreshLogic
- Crisper Bins
- Holiday Mode
- Door Alarm

- 極致保鮮變頻壓縮機
- 防菌淨味系統
- 智能調控面板
- 蔬果保鮮格
- 假日省電模式
- 關門響鬧提示



ESE5301AG-MY

Gross / Net capacity:
總容量 / 淨容量:
541 / 478 Liters / 公升

Fridge / Freezer capacity:
冷藏室 / 冷凍室容量:
313 / 165 Liters / 公升

Dimensions (H x W x D)
體積 (高 x 闊 x 深)
1821 x 923 x 636 mm / 毫米

Freezer star rating:
冷凍室星級:

Color: Silver
顏色: 銀色



ESE6201BG-MY



ESE5301AG-MY

ESE6201BG-MY

Gross / Net capacity:
總容量 / 淨容量:
636 / 594 Liters / 公升

Fridge / Freezer capacity:
冷藏室 / 冷凍室容量:
369 / 225 Liters / 公升

Dimensions (H x W x D)
體積 (高 x 闊 x 深)
1821 x 923 x 706 mm / 毫米

Freezer star rating:
冷凍室星級:

Color: Black
顏色: 黑色

Side-by-side NutriFresh™ Inverter Refrigerator Series

對門極致保鮮變頻雪櫃系列



Model no.	型號	ESE5301AG-MY	ESE6201BG-MY
Gross / Net Capacity (Liter)	總容量/淨容量 (公升)	541 / 478	636 / 594
Fridge Capacity (Liter)	冷藏室容量 (公升)	313	369
Freezer Capacity (Liter)	冷凍室容量 (公升)	165	225
Features	特點		
NutriFresh™ Inverter Technology	極致保鮮變頻技術	•	•
FreshLogic	智能調控面板	•	•
FreshTaste Deodorizer	防菌淨味系統	•	•
Holiday Mode	假日模式	•	•
Child Lock	兒童安全鎖	•	•
Door Alarm	關門響鬧提示	•	•
Frost-free	無霜設計	•	•
Recessed Door Handle	隱藏式門柄	•	•
Fridge Functions	冷藏室功能		
Full Width Door Storage Bins	高身特大層格	4	4
Market Fresh Crisper	蔬果保鮮格	2	2
Spill-proof Glass Shelves	防溢漏強化玻璃層架	5	5
Egg Tray	雞蛋儲存格	•	•
Interior Light	雪櫃照明燈	LED	LED
Freezer Functions	冷凍室功能		
Full Width Door Storage Bins	高身特大層格	3	3
Market Fresh Crisper	蔬果保鮮格	2	2
Twist Ice Cube Bin on Door	旋扭製冰格	•	•
Spill-proof Glass Shelves	防溢漏強化玻璃層架	5	5
Interior Light	雪櫃照明燈	LED	LED
Other Features	其他特點		
Energy Efficiency Rating (Grade)	香港能源效益標籤	1	N.A.
Freezer Star Rating	冷凍室星級	***	***
Refrigerant	環保雪種	R600a	R600a
Dimensions (H x W x D) mm	體積 (高 x 闊 x 深) 毫米	1821 x 923 x 636	1821 x 923 x 706
Dimensions (H x W x D) inch	體積 (高 x 闊 x 深) 吋	71.7 x 36 x 25	71.7 x 36 x 28

* Specifications and design subject to change without notice. All visual images are for reference only.

* 因改進而變更規格，恕不另行通知。所有圖片只供參考。

Dimension & installation guide (mm) 安裝指示圖 (毫米)

Side-by-side NutriFresh™ Refrigerator 對門式變頻雪櫃 ESE530IAG-MY

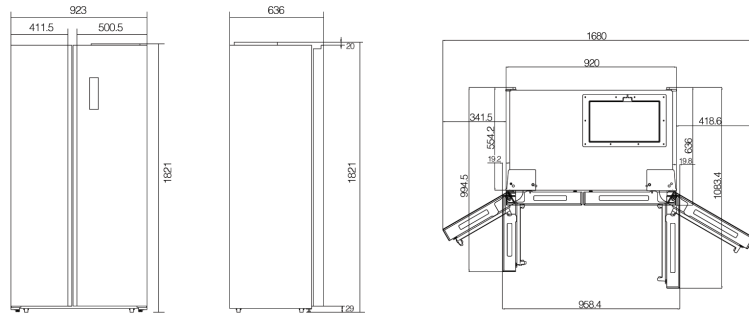

ESE620IBG-MY

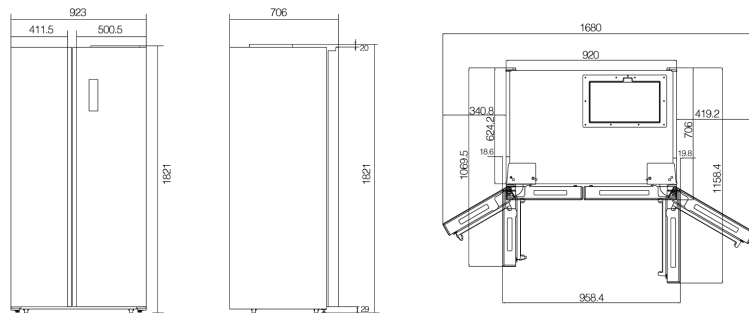

建議通風空間
Recommended airspace

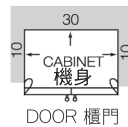

可拆門
Dismantle of doors

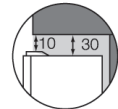

2-door top freezer 上置冰格式 雙門變頻雪櫃

ETB2600MG
ETB3200MG
ETB3500MG

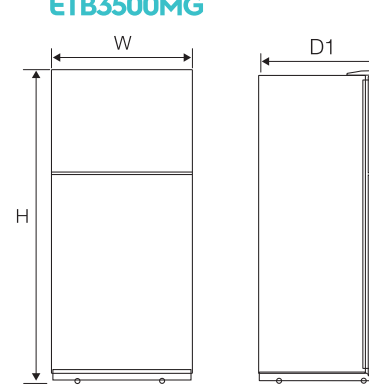

3-door top freezer 上置冰格式 三門變頻雪櫃

EME2600MG
EME3500MG

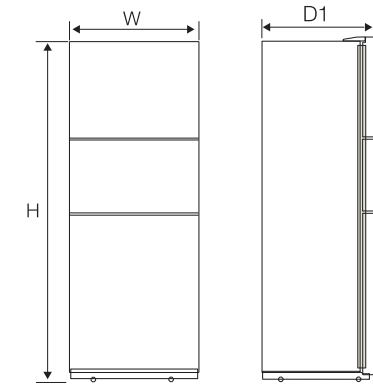

Recommended airspace
建議通風空間

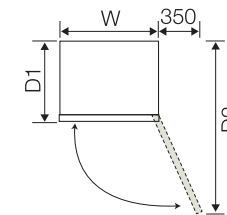
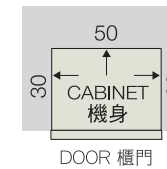

	Total height (H) 總高度 (H)	Total width (W) 總寬度 (W)	Total depth (D1) 總深度 (D1)	Depth door open (D2) 展開櫃門深度 (D2)
2-door NutriFresh Refrigerator, top freezer 上置冰格式雙門變頻雪櫃				
ETB2600MG	1605	540	615	1099
ETB3200MG	1645	598	650	1189
ETB3500MG	1755	598	650	1189
3-door NutriFresh Refrigerator, top freezer 上置冰格式三門變頻雪櫃				
EME2600MG	1745	540	615	1189
EME3500MG	1855	598	650	1189

* Specifications and design subject to change without notice.
All visual images are for reference only.

* 因改進而變更規格，恕不另行通知。
所有圖片只供參考。