

Swedish Thinking. Better Living.

Electrolux strives to improve everyday life for millions of people and the world around us. It is embodied in everything we do. In every idea, every product and every human interaction.

Share more of our thinking at
www.electrolux.com.hk



 Electrolux Hong Kong | 



總代理：
大昌貿易行有限公司

香港九龍灣啟祥道20號大昌行集團大廈五樓
電話：2262 1621

Sole Agent:

DAH CHONG HONG, LTD.

5/F, DCH Building, 20 Kai Cheung Road,
Kowloon Bay, Hong Kong
Tel: 2262 1621

售後服務熱線 **3193 9888**
Service Hotline:



變頻 
極致保鮮

伊萊克斯變頻雪櫃系列
NutriFresh™ Refrigeration

Electrolux_03/20



Swedish Thinking. Better Living.

Electrolux introduces the **NutriFresh™** line of fridges which understands your desire for a healthier and fresh lifestyle by introducing a myriad of features that let you do just that. Cool new features such as 360 Cooling, FlexCool™ and TasterGuard enable you to have flexibility in storing your food keeping them fresher longer so that you can enjoy their wholesome goodness without compromise. Awarded with Grade 1 in Mandatory Energy Efficiency Label (MEEL) from EMSD, the new **Electrolux** fridge range reduces energy consumption.

伊萊克斯深明您對新鮮食材和健康生活的追求，故推出 **NutriFresh™** 雪櫃系列，集結多種高科技功能，包括360度送風氣流、靈活冷藏區及全效防菌淨味等貼心設計，不但得到最佳的冷凍效果，更有效地延長食物保鮮時間。全線伊萊克斯雪櫃系列亦榮獲機電工程署一級能源標籤，節能環保。



Features 雪櫃功能及優點



NutriFresh™ Inverter 極致保鮮變頻技術



- 1 An ungraded compressor prevents temperature fluctuations in order to maintain food freshness and reduces up to 37% energy consumption and much quiet.

* Compared with previous models

全新升級變頻壓縮機，能有效地穩定溫度變化及減少37%的能源消耗。既能保持食材新鮮又能節省用電，運作時更寧靜及安心。

* 與其他較早期型號比較

FreshLogic 智能調控面板



- 3 Easily set the refrigerator multiple functionalities and temperature with FreshLogic on door interface.

設置於門外上的智能調控面板，簡易靈活操作不同功能及調節溫度，狀況一目了然。

TasteGuard 全效防菌淨味



- 2 Reducing stray odour & strong smells from one food mixing with that of others and eliminated 99.8% of bacteria*.

* Independent lab test by Guang Dong Detection Centre of Microbiology.

可減少99.8%引致異味的細菌滋生*，保持食材新鮮無異味，避免影響其他食物的味道。

* 獨立測驗由廣東省微生物分析檢測中心進行

Large Crisper 大容量保鮮格



- 4 The enclosed crisper which maintains the moisture at the optimal level and slowing the foods drying speed according to your needs.

密閉式保鮮格，可按個人需要調控濕度，讓水分不易流失，舒緩食物變乾速度，達至長效保鮮。

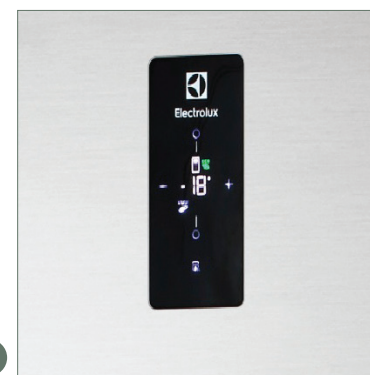

Features 雪櫃功能及優點



FlexStor™ 靈活配置



- 5 FlexStor™ is a flexible door bin storage that can be conveniently adjusted for multiple ways of meeting your needs - from tallest bottles.

雪櫃門上的活動式儲物架，可隨心調動儲存空間，能輕易地騰出空間儲存高身瓶裝飲品。

360 Cooling 360 度送風氣流



- 7 The 360 cooling circulates air throughout the entire fridge, so each compartment and shelf is cooled evenly and at a consistent temperature.

設有多層出風口，將冷空氣傳到雪櫃的每個角落，讓溫度更均勻穩定，確保食物充分冷凍。

FlexCool™ 靈活冷藏區



- 6 FlexCool™ which can be configured to store a variety of refrigeration requirements at the ideal freezing level. (Storage temperature -12°C to +3°C)

根據不同需要，靈活調節轉換由攝氏負12度至3度的溫度，達至最佳冷凍效果。



* Above descriptions only apply to particular model.
以上功能視乎型號。

Features 雪櫃功能及優點



Holiday Mode 假日省電模式



8

Holiday mode is designed to take advantage of maximum energy efficiency when you will be away from your appliance for an extended period. Auto-alteration will start after 30hrs no human interaction.

當超過30小時沒有開啟雪櫃或觸控智能面板，自動調節模式將會啟動，設備將以最少電量運作，確保食物質素。

Quick Freeze Mode 快速冷凍模式



10

Use the quick freeze mode when you add a large amount of new fresh food to the freezer compartment. The freezer compartment temperature will reach to -23°C quickly. This quick freeze mode can retain the freshness and also avoid the new contents affect the temperature to existing contents.

當儲存大量食品時，快速冷凍模式可以使冷凍室溫度迅速降至 -23°C ，快速冷凍新鮮食物，同時亦可避免室溫食物影響冷凍室原有已存的食物溫度。

Door Alarm 關門響鬧提示



9

Door alarm which ensures that your refrigerator can never be accidentally left open. Now you can save energy without compromising on safe food storage.

不用再擔心忘記關上雪櫃門。當雪櫃門開啟超過一定時間，會自動發出聲響提示關門，避免因為雪櫃門未關而增加耗電，或是令食物變壞。

8



9



10



* Above descriptions only apply to particular model.
以上功能視乎型號。



ETB2802H

2-door NutriFresh™ Refrigerator, Top Freezer
上置冰格式雙門變頻雪櫃



- NutriFresh™ Inverter
- TasteGuard
- 360° Cooling
- Large Crisper
- Door Alarms

Gross / Net capacity: 總容量 / 淨容量:
275 / 255 Liters 275 / 255 公升

Fridge / Freezer capacity: 冷藏室 / 冷凍室容量:
194 / 61 Liters 194 / 61 公升

Dimensions (H x W x D) 體積 (高 x 闊 x 深)
1605 x 540 x 615 mm 1605 x 540 x 615 毫米

Freezer star rating: 冷凍室星級:
★★★★

Color: Arctic Silver 顏色: 北極銀

- 極致保鮮變頻
- 全效防菌淨味
- 360度送風氣流
- 大容量保鮮格
- 關門響鬧提示



ETB3400H / ETB3700H

2-door NutriFresh™ Refrigerator, Top Freezer
上置冰格式雙門變頻雪櫃



- NutriFresh™ Inverter
- TasteGuard
- 360° Cooling
- Large Crisper
- Door Alarms
- Reversible Door (Advance Notice)

Gross / Net capacity: 總容量 / 淨容量:
339 / 316 Liters (ETB3400H) 339 / 316 公升 (ETB3400H)
369 / 348 Liters (ETB3700H) 369 / 348 公升 (ETB3700H)

Fridge / Freezer capacity: 冷藏室 / 冷凍室容量:
241 / 75 Liters (ETB3400H) 241 / 75 公升 (ETB3400H)
273 / 75 Liters (ETB3700H) 273 / 75 公升 (ETB3700H)

Dimensions (H x W x D) 體積 (高 x 闊 x 深)
1645 x 598 x 650 mm (ETB3400H) 1645 x 598 x 650 毫米 (ETB3400H)
1755 x 598 x 650 mm (ETB3700H) 1755 x 598 x 650 毫米 (ETB3700H)

Freezer star rating: 冷凍室星級:
★★★★

Color: Arctic Silver 顏色: 北極銀

- 極致保鮮變頻
- 全效防菌淨味
- 360度送風氣流
- 大容量保鮮格
- 關門響鬧提示
- 可轉換左右門 (需預先通知)



EME2600MG

3-door NutriFresh™ Refrigerator, Top Freezer
上置冰格式三門變頻雪櫃



- NutriFresh™ Inverter
- TasteGuard
- FreshLogic
- 360 Cooling
- Large Crisper
- FlexCool™
- FlexStor™
- Holiday Mode
- Quick Freeze Mode
- Door Alarm

Gross / Net capacity:
279 / 252 Liters

總容量 / 淨容量:
279 / 252 公升

Fridge / Freezer / FlexCool™ capacity:
149 / 62 / 41 Liters

冷藏室 / 冷凍室 /
靈活冷藏區容量:
149 / 62 / 41 公升

Dimensions (H x W x D)
1745 x 540 x 615 mm

體積 (高 x 闊 x 深)
1745 x 540 x 615 毫米

Freezer star rating:

冷凍室星級:

Color: Dark Grey

顏色: 銀影灰

- 極致保鮮變頻
- 全效防菌淨味
- 智能調控面板
- 360度送風氣流
- 大容量保鮮格
- 靈活冷藏區
- 靈活配置
- 假日省電模式
- 快速冷凍模式
- 關門響鬧提示



EME3700H

3-door NutriFresh™ Refrigerator, Top Freezer
上置冰格式三門變頻雪櫃



- NutriFresh™ Inverter
- TasteGuard
- FreshLogic
- 360 Cooling
- Large Crisper
- FlexCool™
- FlexStor™
- Holiday Mode
- Quick Freeze Mode
- Door Alarm

Gross / Net capacity:
363 / 332 Liters

總容量 / 淨容量:
363 / 332 公升

Fridge / Freezer / FlexCool™ capacity:
206 / 75 / 51 Liters

冷藏室 / 冷凍室容量 /
靈活冷藏區容量:
206 / 75 / 51 公升

Dimensions (H x W x D)
1855 x 598 x 650 mm

體積 (高 x 闊 x 深)
1855 x 598 x 650 毫米

Freezer star rating:

冷凍室星級:

Color: Arctic Silver

顏色: 北極銀

- 極致保鮮變頻
- 全效防菌淨味
- 智能調控面板
- 360度送風氣流
- 大容量保鮮格
- 靈活冷藏區
- 靈活配置
- 假日省電模式
- 快速冷凍模式
- 關門響鬧提示

2-door / 3-door Nutrifresh Inverter Refrigerator Series

雙門 / 三門極致保鮮變頻雪櫃系列



Model no.	型號	ETB2802H	ETB3400H	ETB3700H	EME2600MG	EME3700H
Gross/Net Capacity (Liter)	總容量/淨容量 (公升)	275 / 255	339 / 316	369 / 348	279 / 252	363 / 332
Fridge Capacity (Liter)	冷藏室容量 (公升)	194	241	273	149	206
Freezer Capacity (Liter)	冷凍室容量 (公升)	61	75	75	62	75
FlexCool™ Capacity (Liter)	靈活冷藏區容量 (公升)	-	-	-	41	51
Features	特點					
NutriFresh™ Inverter	極致保鮮變頻技術	•	•	•	•	•
FreshLogic	智能調控面板	-	-	-	•	•
360 Cooling	360度送風氣流	•	•	•	•	•
TasteGuard	全效防菌淨味	•	•	•	•	•
ECO Mode	節能模式	-	-	-	•	-
Holiday Mode	假日模式	-	-	-	•	•
Drink Chill Mode	飲品急凍模式	-	-	-	•	-
Door Alarm	關門響鬧提示	•	•	•	•	•
Frost-free	無霜設計	•	•	•	•	•
Recessed Door Handle	隱藏式門柄	•	•	•	•	•
Fridge Functions	冷藏室功能					
Door Storage Bins (Shelves)	活動式層格	2	3	3	3	4
Door Storage Bins (Full Width)	特大層格 (高身飲品用)	2	2	2	2	2
Large Crisper	大容量保鮮格	1	1	1	1	1
Fridge Glass Shelves	玻璃層架	2	2	2	3	2
Chill Room	保鮮室	•	•	•	-	•
Bag Clips/Hooks	專利門架夾子	-	-	-	2	-
Egg Tray	雞蛋儲存架	•	•	•	•	•
Interior Light	雪櫃照明燈	LED	LED	LED	LED	LED
Freezer Functions	冷凍室功能					
Quick Freeze Mode	快速冷凍模式	-	-	-	•	•
Door Storage Bins (Shelves)	活動式層格	2	2	2	2	2
Ice Tray	製冰格	Tray冰格	Twist旋扭式	Twist旋扭式	Twist旋扭式	Twist旋扭式
Freezer Shelf	冷凍室層架	Plastic塑膠	Glass玻璃	Glass玻璃	Glass玻璃	Glass玻璃
Other Features	其他特點					
Energy Grade	香港能源效益級別	1	1	1	1	1
Freezer Star Rating	冷凍室星級	***	***	***	***	***
Refrigerant	環保雪種	R600a	R600a	R600a	R600a	R600a
Dimensions (H x W x D) mm	體積 (高 x 闊 x 深) 毫米	1605 x 540 x 615	1645 x 598 x 650	1755 x 598 x 650	1745 x 540 x 615	1855 x 598 x 650
Dimensions (H x W x D) inch	體積 (高 x 闊 x 深) 吋	63.2 x 21.3 x 24.2	64.8 x 23.5 x 25.6	69.1 x 23.5 x 25.6	68.7 x 21.3 x 24.2	73 x 23.5 x 25.6
Reversible Door (Advance notice)	可轉換左右門 (需預先通知)	-	•	•	-	-
Country of Origin	原產地	Thailand 泰國	Thailand 泰國	Thailand 泰國	Thailand 泰國	Thailand 泰國

* Specifications and design subject to change without notice.
All visual images are for reference only.

* 因改進而變更規格，恕不另行通知。
所有圖片只供參考。

Side-by side Refrigerator 對門式雪櫃



ESE6201BG-MY



ESE5301AG-MY

ESE5301AG-MY / ESE6201BG-MY

Side-by-side NutriFresh™ Refrigerator
對門式變頻雪櫃



ESE5301AG-MY

Gross / Net capacity:
總容量 / 淨容量:
541 / 478 Liters / 公升

Fridge / Freezer capacity:
冷藏室 / 冷凍室容量:
313 / 165 Liters / 公升

Dimensions (H x W x D)
體積 (高 x 闊 x 深)
1821 x 923 x 636 mm / 毫米

Freezer star rating:
冷凍室星級:
★★★★

Color: Silver
顏色: 銀色

ESE6201BG-MY

Gross / Net capacity:
總容量 / 淨容量:
636 / 594 Liters / 公升

Fridge / Freezer capacity:
冷藏室 / 冷凍室容量:
369 / 225 Liters / 公升

Dimensions (H x W x D)
體積 (高 x 闊 x 深)
1821 x 923 x 706 mm / 毫米

Freezer star rating:
冷凍室星級:
★★★★

Color: Black
顏色: 黑色

- NutriFresh™ Inverter
- TasteGuard
- FreshLogic
- Large Crisper
- Holiday Mode
- Door Alarm

- 極致保鮮變頻
- 全效防菌淨味
- 智能調控面板
- 大容量保鮮格
- 假日省電模式
- 關門響鬧提示

Side-by-side NutriFresh™ Inverter Refrigerator Series

對門極致保鮮變頻雪櫃系列



Model no.	型號	ESE5301AG-MY	ESE6201BG-MY
Gross / Net Capacity (Liter)	總容量/淨容量 (公升)	541 / 478	636 / 594
Fridge Capacity (Liter)	冷藏室容量 (公升)	313	369
Freezer Capacity (Liter)	冷凍室容量 (公升)	165	225
Features	特點		
NutriFresh™ Inverter	極致保鮮變頻技術	•	•
FreshLogic	智能調控面板	•	•
TasteGuard	全效防菌淨味	•	•
Holiday Mode	假日模式	•	•
Child Lock	兒童安全鎖	•	•
Door Alarm	關門響鬧提示	•	•
Frost-free	無霜設計	•	•
Recessed Door Handle	隱藏式門柄	•	•
Fridge Functions	冷藏室功能		
Full Width Door Storage Bins	高身特大層格	4	4
Market Fresh Crisper	蔬果保鮮格	2	2
Spill-proof Glass Shelves	防溢漏強化玻璃層架	4	4
Egg Tray	雞蛋儲存格	•	•
Interior Light	雪櫃照明燈	LED	LED
Freezer Functions	冷凍室功能		
Full Width Door Storage Bins	高身特大層格	3	3
Large Crisper	大容量保鮮格	2	2
Twist Ice Cube Bin on Door	旋扭製冰格	•	•
Spill-proof Glass Shelves	防溢漏強化玻璃層架	5	5
Interior Light	雪櫃照明燈	LED	LED
Other Features	其他特點		
Energy Efficiency Rating (Grade)	香港能源效益標籤	1	-
Freezer Star Rating	冷凍室星級	***	***
Refrigerant	環保雪種	R600a	R600a
Dimensions (H x W x D) mm	體積 (高 x 闊 x 深) 毫米	1821 x 923 x 636	1821 x 923 x 706
Dimensions (H x W x D) inch	體積 (高 x 闊 x 深) 吋	71.7 x 36 x 25	71.7 x 36 x 28

* Specifications and design subject to change without notice.
All visual images are for reference only.

* 因改進而變更規格，恕不另行通知。
所有圖片只供參考。

Dimension & installation guide (mm)

安裝指示圖 (毫米)

Side-by-side NutriFresh™ Refrigerator
對門式變頻雪櫃

ESE530IAG-MY

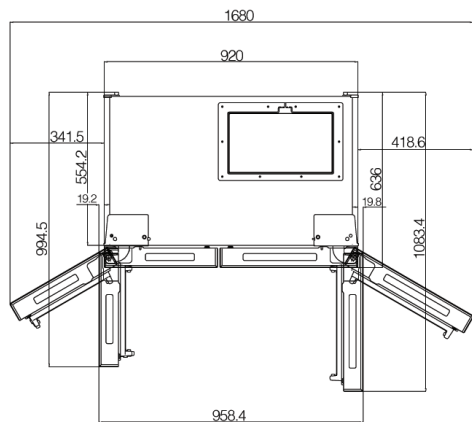
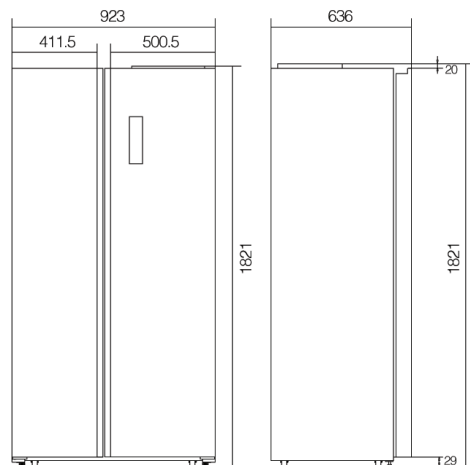

ESE620IBG-MY

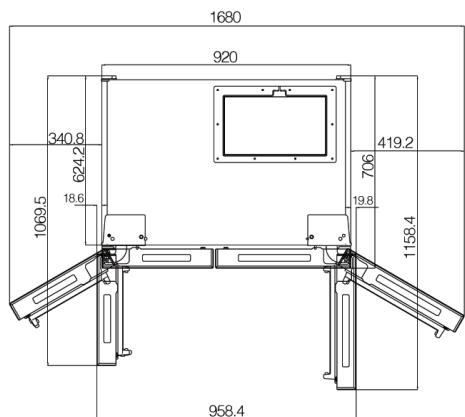
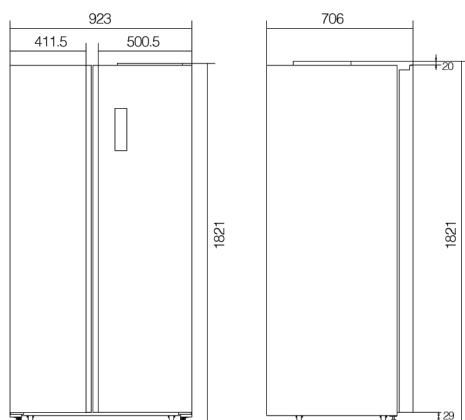

Recommended airspace
建議通風空間

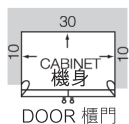

*可拆門 Dismantle of doors

2-door top freezer
上置冰格式
雙門變頻雪櫃

ETB2802H
ETB3400H
ETB3700H

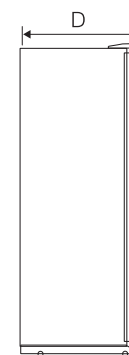
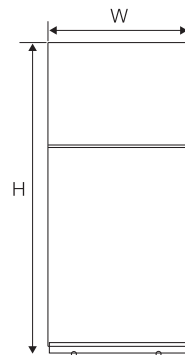

3-door top freezer
上置冰格式
三門變頻雪櫃

EME2600MG
EME3700H

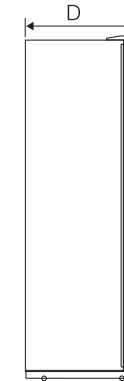
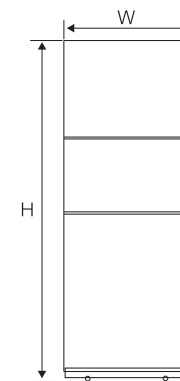

Recommended airspace
建議通風空間

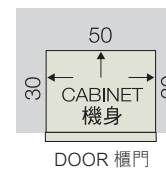

Total height (H)
總高度 (H)

Total width (W)
總寬度 (W)

Total depth (D)
總深度 (D)

2-door NutriFresh Refrigerator, top freezer 上置冰格式雙門變頻雪櫃

ETB2802H	1605	540	615
ETB3400H	1645	598	650
ETB3700H	1755	598	650

3-door NutriFresh Refrigerator, top freezer 上置冰格式三門變頻雪櫃

EME2600MG	1745	540	615
EME3700H	1855	598	650

* Specifications and design subject to change without notice.
All visual images are for reference only.

* 因改進而變更規格，恕不另行通知。
所有圖片只供參考。



Electrolux Home Care Service

- 5 years full warranty for 2-door & 3-door refrigerator / 3 years full warranty for side-by-side refrigerator
- 10 years warranty on inverter compressor
- 60 days free machine replacement for defective items

- 5年全機保養（2門及3門雪櫃）/ 3年全機保養（對門雪櫃）
- 10年變頻壓縮機保養
- 60日壞機包換

Please refer to our website for detail service terms & conditions:
服務範圍及各事項詳情，請參閱：
www.dch-ead.com